

The logo for VelocityEHS, featuring the word "Velocity" in a white, italicized sans-serif font and "EHS" in a white, bold sans-serif font, with a registered trademark symbol (®) to the upper right of "EHS".

*Velocity*EHS[®]

Designing Better Controls for Ergonomics

Rachel Zoky, CPE • Rick Barker, CSP, CPE • Blake McGowan, CPE

March 20, 2024

Agenda

- Introduction
- Using Design Principles
- Applying Design Guidelines
- Verifying Control Effectiveness
- Employing Lessons Learned



Two Related Design Challenges in Ergonomics

- Changes to existing workplace
- Design of new workplaces (Prevention-through-Design)



Common Current State

Existing Work Environment

- Equipment changed to fit specific (or first shift) worker
- Little or no verification of control effectiveness
- Limited application of effective controls to similar jobs
- Limited awareness of MSD risk

New Design

- Ergonomics isn't involved until reviewing the built or purchased equipment (Limited resources to make expensive changes)
- Updates made on existing equipment aren't incorporated into new designs
- Responsibility for considering ergonomics isn't established



Four Tools for Improving Controls in Ergonomics

- Principles of Ergonomics for Design
- Design Guidelines for Ergonomics
- Verification of Controls
- Lessons Learned



Principles of Ergonomics for Design



Application and Limitations of Design Principles

When should you focus on Design Principles?

Applications

- Evaluating a new product design/proposal (accessibility, number of parts, etc.)
- Design Trade-off evaluations
 - » Completing risk factors
 - » Level of impact of risk

Limitations

- Lack specificity
- Requires more expertise and experience to apply correctly



Design Principles: Product Engineers

- Avoid part fits that will result in the operator striking the parts with the hand to obtain a fit
- Provide sufficient sensory feedback (primarily tactile) for operators to verify connection
- Minimize the number of component parts, especially fasteners
- Design parts for ease of alignment
- Mistake-proof component parts to ensure "one way - right way" assembly
- Provide sufficient visual access, especially for critical connection
- Ensure that fit and force requirements are not impacted by parts at extremes of tolerance (adequate tolerance provided for parts stack-up)



Using Design Principles: New Product Designs

What do I analyze before official CAD designs?

- 3D print prototype parts
 - » Grip locations
 - » Estimated weights/assembly forces
 - » Access spacing
 - » Number of attachments

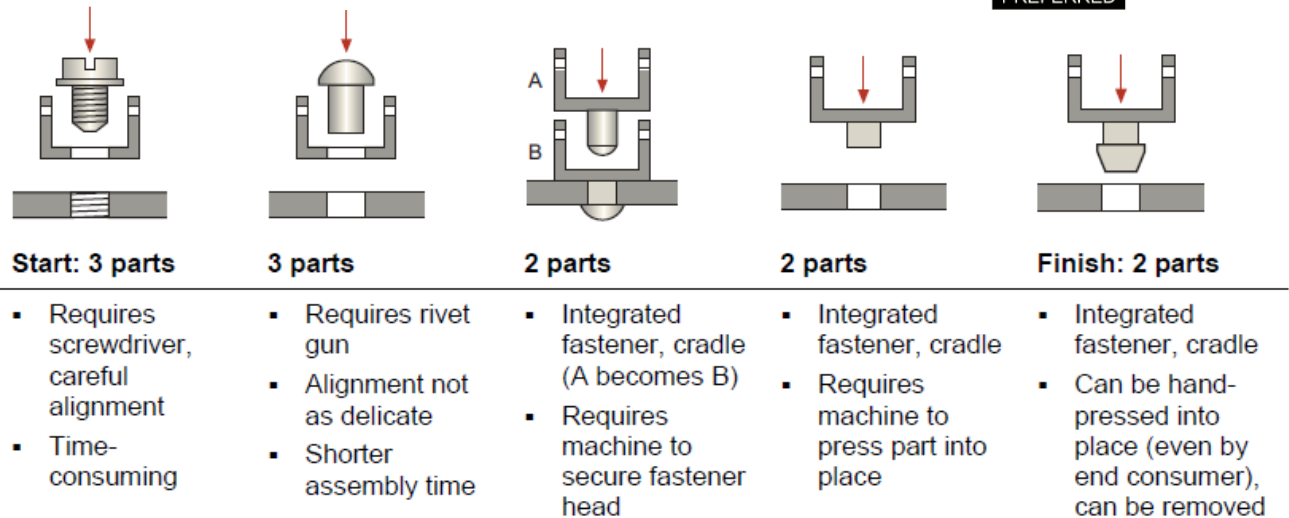
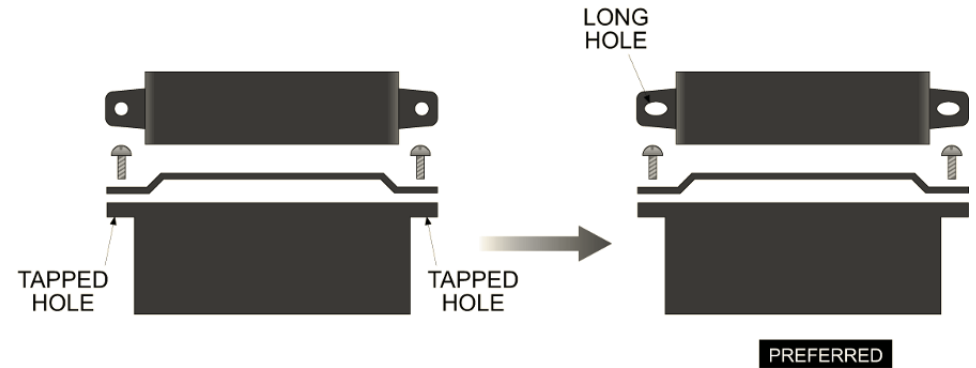

Design Principles: Manufacturing Engineers

When should you Design for the Average?

- First Choice: Design for Adjustability
 - » Large/awkward handheld components
 - » High forces
 - » High frequency/fast-paced work
- Otherwise, Design for Extremes
 - » Clearances for the largest or tallest (95th%ile male)
 - » Reaches for the smallest of shortest (5th%ile female)



US Average Men's size: 10.5
US Average Women's size: 8.5
(size 7 in men's)

Everyone gets a size 9!



Using Design Principles: Existing Work Environments

Prioritize risk factors that are present based on level of impact

- What type of work is being performed at this station?
 - » High precision/ Very detailed
 - » General assembly
 - » High force
- How often is this job being performed?
- What is the “worst-case scenario” of this work being performed?
 - » i.e. shortest operator or tallest? Biggest operator or smallest?

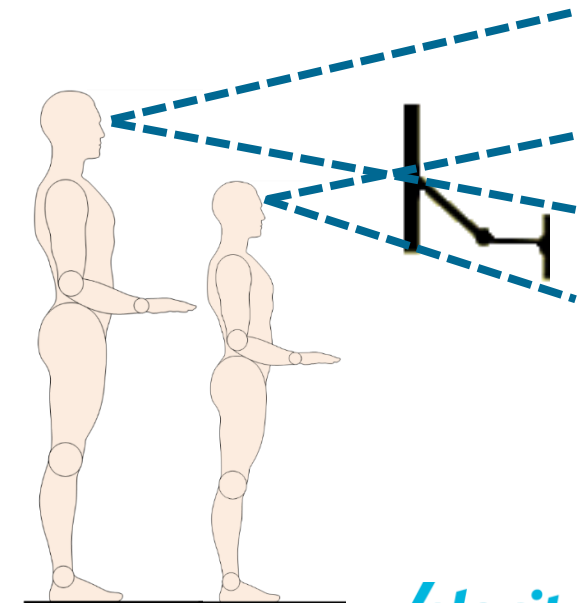
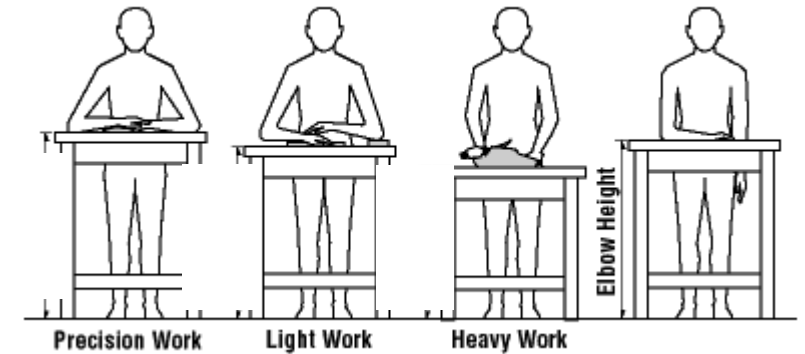

Using Design Principles: New Equipment Designs

What do I analyze before official CAD designs?

- Review material flow through station
 - » Verify accessibility to grab and place components
 - Do fixture tolerances align with component tolerances?
 - » Evaluate design of material racks/carts/ etc.
 - Fixed height vs adjustable height
 - Spacing requirements (impact of packaging?)
 - » Evaluate impact of environment on flow (i.e. lighting, spacing with other lines, guarding, etc.)
 - » Can components be loaded incorrectly?



Cardboard mock-ups of the theoretical equipment, workstations, fixtures, and current hand tools

Printed reference information such as current part designs, timed task lists, current layout design, etc.



Design Guidelines for Ergonomics



Applications and Limitations of Design Guidelines

When should you focus on Design Guidelines?

Applications

- Evaluating an existing design/workstation
- Specific dimensions for a single category
 - » Defined rules for a given result
- Easy for non-experts to apply

Limitations

- Multiple risk factors interacting
 - » ex. Trade-off in guarding between safety and ergonomics



Tip For More Effective Design Guidelines

Say What You Mean/Define Actions

Optimal	"Optimal" guidelines are best case scenarios, often requiring adjustability. Optimal designs are most applicable for jobs with high ergonomics demands
Meets Standard	"Meets Standard" is the target design that should result in minimal risk exposure to employees for most job tasks
Further Assessment	"Further Assessment" applies to the range that may or may not minimize risk exposure to employees, depending on the specific situation. Any design criteria that falls in the "Further Assessment" range shall be reviewed with an ergonomics specialist prior to approving the design.
Criteria Not Met	If it is not technically or financially feasible to meet the design criteria, the ergonomist will complete a preliminary risk assessment. If the design is projected to have a high risk of MSD, Senior Leadership must acknowledge and approve the risk exposure.



Examples of Design Guidelines

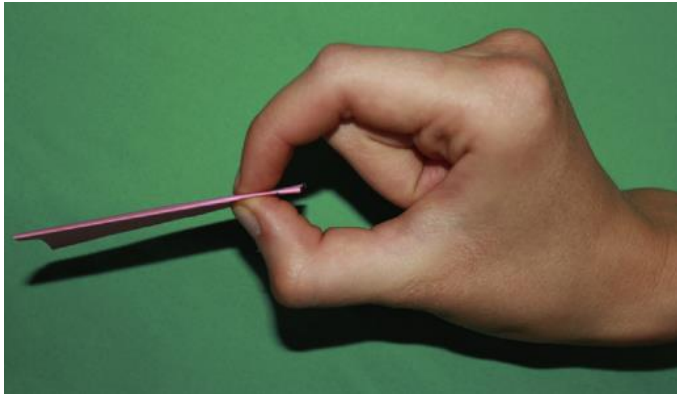

Chuck Pinch Grip



Key Pinch Grip

Design Guidelines for Ergonomics

Menu

Hand Strength – All Populations

Force Exertions: Pinch Grip	One-Handed Pinch Grip Force			
	Frequent ($\geq 2/\text{min.}$)		Infrequent ($< 2/\text{min.}$)	
	Recommended	Acceptable	Recommended	Acceptable
Chuck pinch grip* (with wrist deviation†)	2.0 lb (0.9 kg)	2.4 lb (1.1 kg)	4.0 lb (1.8 kg)	5.1 lb (2.3 kg)
Chuck pinch grip (no wrist deviation)	3.2 lb (1.4 kg)	4.7 lb (2.1 kg)	7.9 lb (3.6 kg)	10.3 lb (4.7 kg)
Key pinch grip‡ (with wrist deviation)	2.0 lb (0.9 kg)	2.9 lb (1.3 kg)	4.8 lb (2.2 kg)	6.3 lb (2.9 kg)
Key pinch grip (no wrist deviation)	3.9 lb (1.8 kg)	6.0 lb (2.7 kg)	9.7 lb (4.4 kg)	12.6 lb (5.7 kg)

* Thumb opposing pads of index, middle fingers
 † Noticeable flexion, extension, ulnar, radial
 ‡ Thumb opposing side of index finger

Using Design Guidelines: New Product Designs

Start with orienting yourself to where the operator will be positioned while accessing the product

- Identify which design guidelines you need to evaluate against
 - » Component Assembly Forces
 - » Accessibility
- Review order of component assembly and origin of each component
 - » Separated vs bulk parts presentation
 - » Top-down vs bottom-up assembly
 - » Impact on part materials of environmental factors (i.e. heat, humidity, sunlight, etc.)



Examples of Design Guidelines (Cont'd)

- Manual material handling guidelines established for different global populations
- Optimal Zone (Green Zone)
 - » 5th percentile female elbow height
 - » 95th percentile male elbow height
- Comfort Zone (Yellow Zone)
 - » 5th percentile female shoulder height
 - » 95th percentile male knee height
- Extended Zone (Red Zone)
 - » 5th percentile female height plus 300 mm (ACGIH Guideline)
 - » 95th percentile male mid-shin height

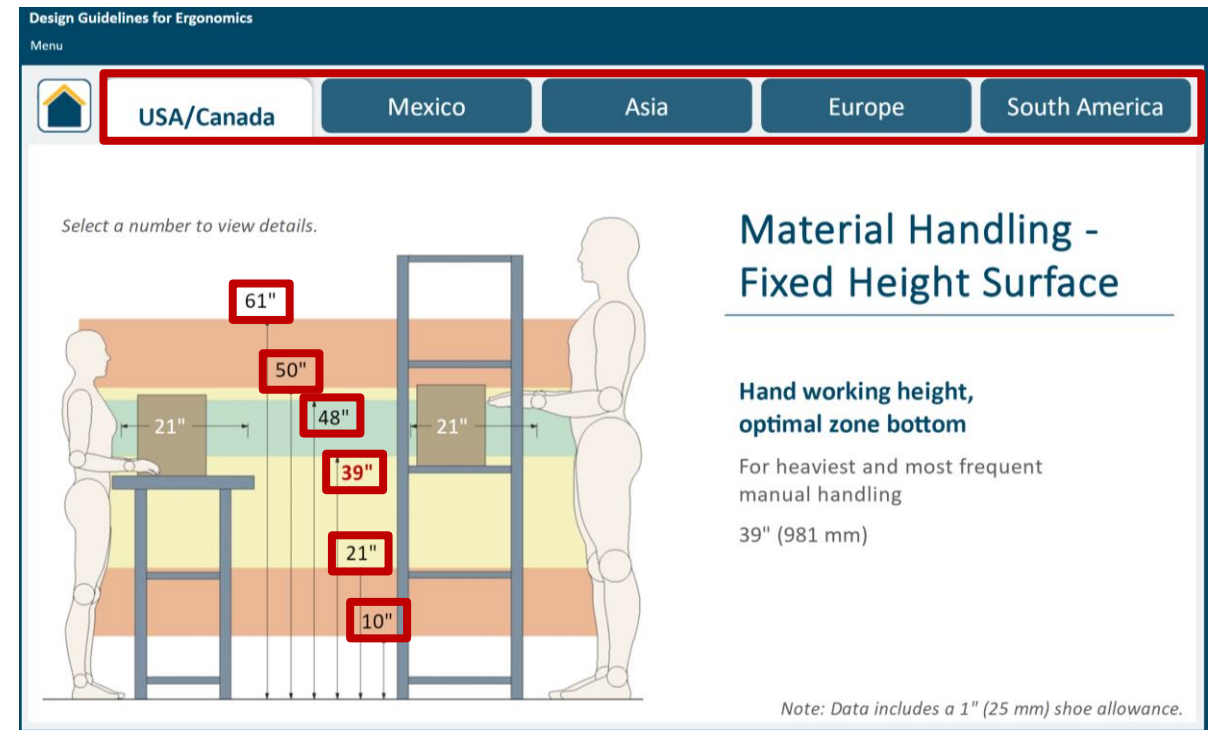

Using Design Guidelines: Existing Work Environments

Which MSD Risk Factors are present?

- Identify which design guidelines are relevant to the situation
 - » Ex: 2-handed push strength, Horizontal handle height, etc.
- Compare existing measurements to design guidelines
 - » Ex: Current force to move drum vs Recommended force to push drum cart

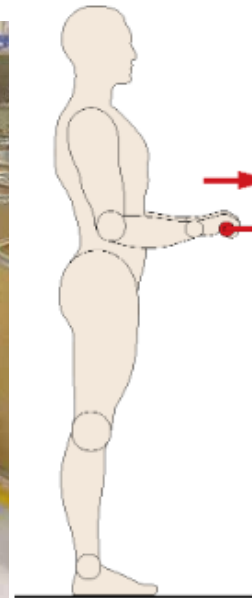

High forces to manually maneuver 80-lb drums.

Provided drum cart to improve postures and reduce force exertions.

Using Design Guidelines: New Equipment Designs

Start with identifying which design guidelines you need to evaluate against

Some questions to ask:

- Where is this equipment going to be located?
 - » Choose the correct population related design guidelines
- What is the weight of the parts involved?
- How often will this job be performed?
 - » Is this a frequent or infrequent job based on cycle time?

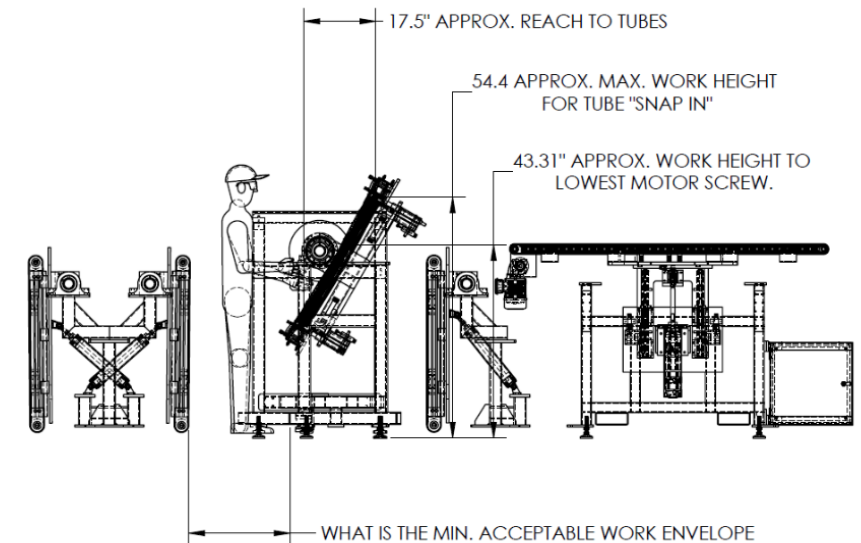

Using Design Guidelines: New Equipment Designs

Identify and record relevant design dimensions

- Choose the worst-case scenario, if it's acceptable, everything else will be ok too
 - » Hand Working Height
 - » Horizontal Reach
 - » Parts presentation
 - » Suspended Tool Height
- What is the status of each dimension?
 - » Within Guideline Range
 - Low risk of any musculoskeletal disorder, no change necessary
 - » Outside of Design Guidelines
 - Recommended: Follow company-specific deviation process
 - Generate plan for change



Ergonomics Gate Keeper

Who decides whether or not a design is acceptable?

Especially when a dimension falls outside of the design guideline, someone needs to be responsible for approving or rejecting the design.

- Criteria for Authority:
 - » Not directly responsible for engineering the design
 - » Responsible for the MSD risk level within the manufacturing plant
 - » Has the Authority to make approval/deny delivery
- Plant Manager is highly recommended

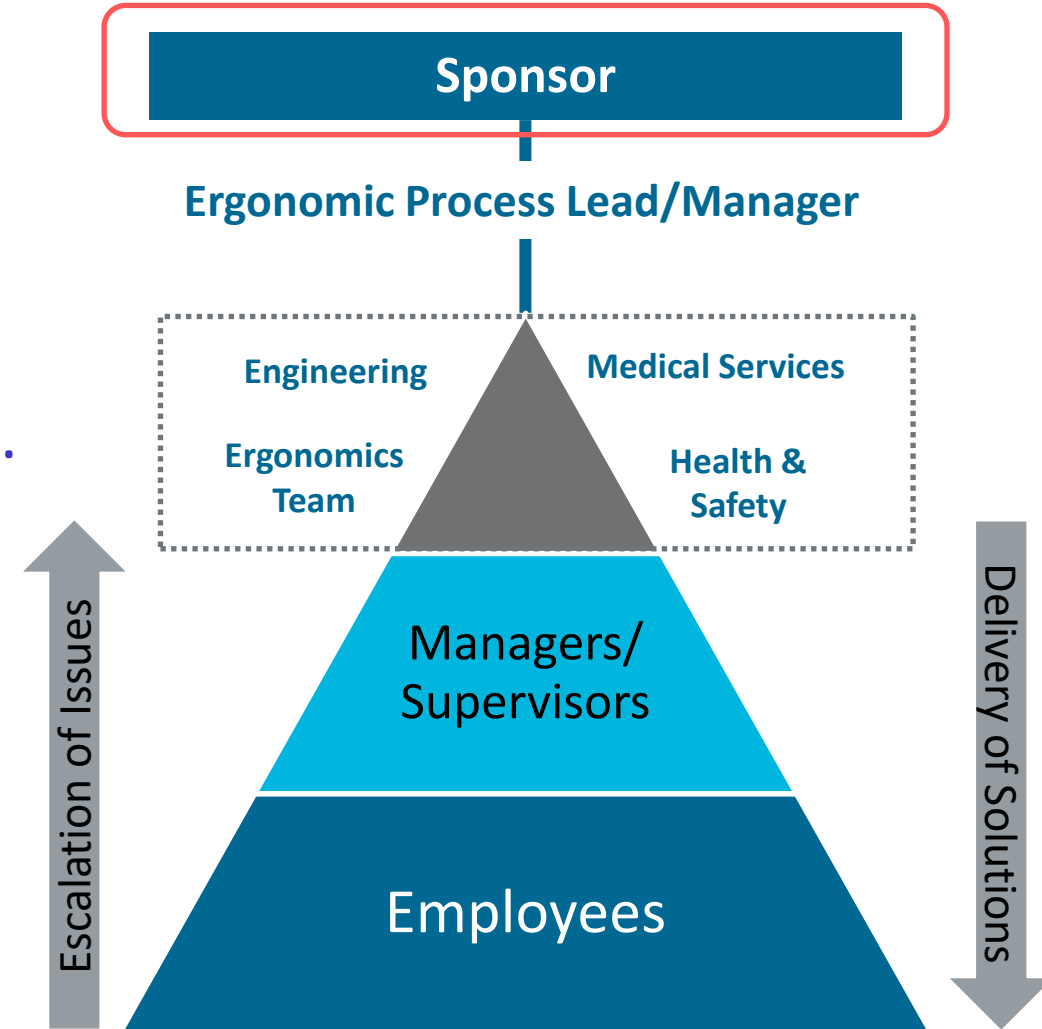

Verification of Controls



Why Verify Controls

- Generate “proof” of risk reduction related to an investment of resources
 - » 2 data points can be used to estimate ROI and create buy-in for future resource requests
- Ensure that control implementation is complete
 - » Operators are aware of the change and trained in any new processes/equipment
- Iterative or incremental improvements without a follow-up analysis at each stage of the roll-out to verify the risk level can result in a lost opportunity to correct your plan before it is costly

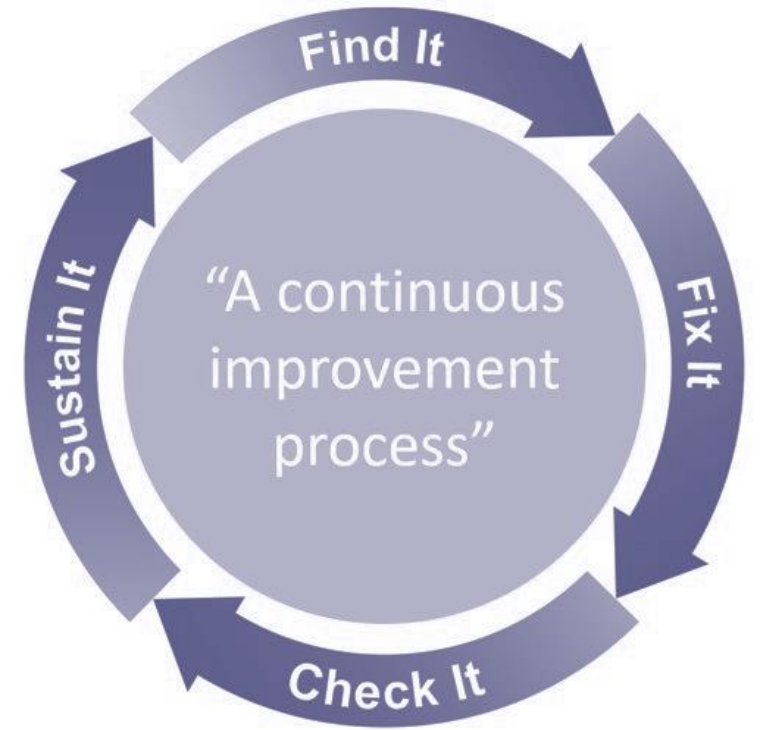

How to Verify Ergonomic Controls

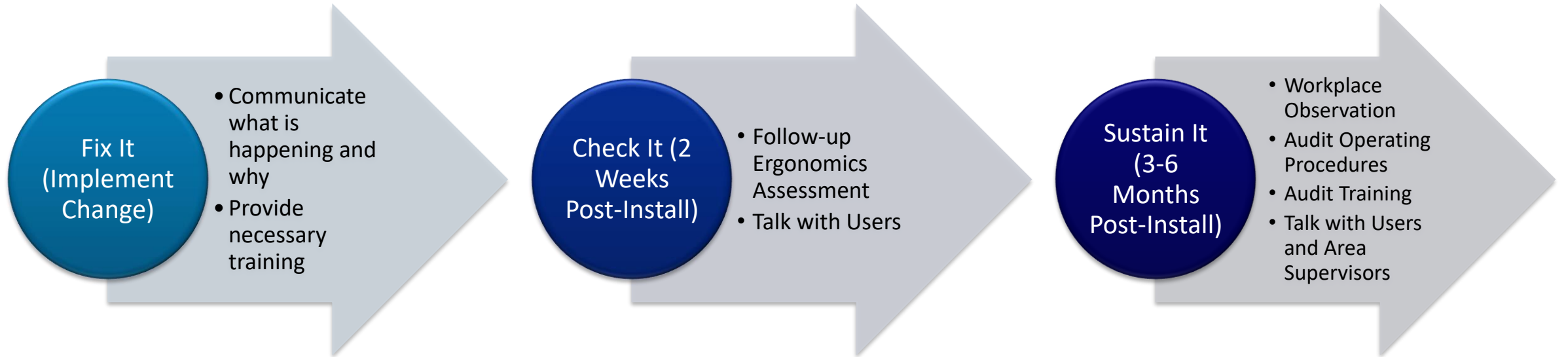

Lessons Learned



Look Across in Existing Work Environment

Fix once, Repeat many

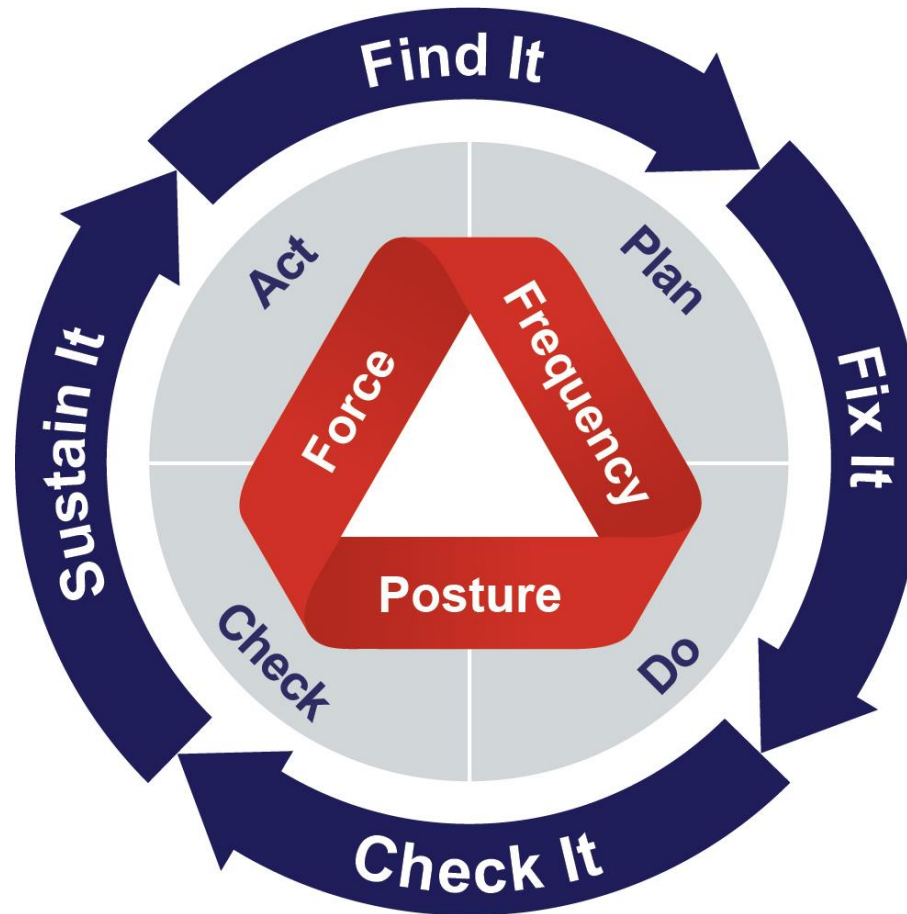

Incorporating into New Design

- Verified Controls
- Unresolved MSD Risk Exposures
- Avoid repeating costly mistakes



Prioritizing Unresolved Risk

- List all unresolved high-risk tasks in existing or similar product along with the causal factors for each risk
- Rate or rank the severity of risk exposure
- Sort the causes into types (e.g. product design, tool design, process flow)
- Review the sorted list with engineers in that and rate the difficulty to address the underlying cause
- Use a severity/difficulty matrix to obtain agreement with project team on design priorities for ergonomics



Interactive Ergonomics Program Self-Assessment

Scan the QR code to quickly assess your current program. You'll get **easy-to-read results & customized recommendations** for improvement.



Questions?



Rachel Zoky, CPE
Senior Strategic
Consultant



**Rick Barker, CSP,
CPE**
Sr. Director,
Solution Strategy



Blake McGowan, CPE
Solution Executive

